

SECTION A-A

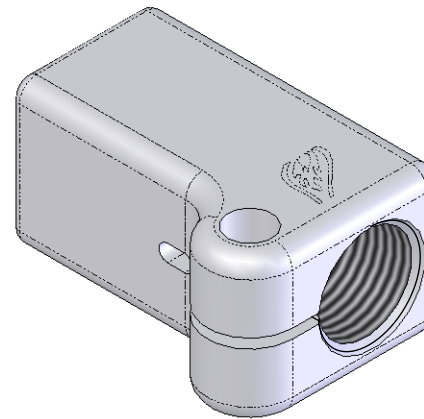

Specialty Products Company
 Longmont, Colorado USA • www.specprod.com

LINEAR mm[in] ANGLE (deg.)
 None \pm 1.00 [X \pm .040"] None \pm 2.0°
 .X \pm 0.50 [XX \pm .020"] .X \pm 1.0°
 .XX \pm 0.25 [XXX \pm .010"] .XX \pm 0.5°
 CONFORMS TO
 ASME Y14.5

15150

MATERIAL: 4140 PER SAE ASTM A 331
 FINISH: None