

SPC

PERFORMANCE®

This part should only be installed by personnel who have the necessary skill, training and tools to do the job correctly and safely. Incorrect installation can result in personal injury, vehicle damage and / or loss of vehicle control.

Plan Ahead - Read All Instructions BEFORE installing part.

Note: Combining these arms with other suspension components can sometimes result in unworkable or unsafe combinations. Consult a professional installer if you are unsure about your intended configuration. SPC cannot provide advice on overall system suitability.

Ride Height: With all other vehicle parts and settings unchanged, these arms will lower the front of the car by approximately 0.75" - this is with the arms as supplied with bolt-in spring seats mounted directly to the arm. A ride height shim kit is available (p/n 95332) that can increase ride height in approximately 0.5" increments. Confirm that the 'clocking' of the spring seat "step" is roughly equivalent to the stock arm (factory setting), it should be to the right of straight up (see **Figure 1**). Additional seat positions are feasible which may be helpful for some aftermarket springs but may prevent the use of ride height shims.

Suspension Travel: For all custom setups, maximum suspension uptravel should be checked for adequate shock travel and tire/fender clearances.

Alignment: The arms will add approximately 2° of positive caster to the car. When used in combination with SPC adjustable upper arms, p/n 94340 correct caster for radial tires can be set while keeping the tires approximately centered in the wheel well openings for best possible clearances in turns.

Coil-over Shocks: If you are using 'coil-overs' instead of conventional springs and shocks, you will need to remove the aluminum spring seats and replace them with SPC's p/n 95338 to provide the necessary reinforcement to handle the different loading conditions on the arm that coil-overs generate.

Installation: This lower arm set is a direct bolt-in replacement for stock arms.

1. Prepare each arm by greasing and inserting the metal tubes into Delrin pivot bushings. Install supplied grease fittings in the underside of the bushing end-rings. Install jounce bumper.

NOTE: SPC recommends our optional cup-mounted urethane bump stops (p/n 95339) to replace your hard-rubber originals for improved ride quality and bottoming protection.

2. Remove OEM arms and install SPC arms. Springs and shocks will need to be removed and reinstalled during this process.

Note: Certain combinations of headers and springs may require an internal spring compressor (SPC p/n 40250) to ease installation.

3. Lower vehicle to rest on tires. If on slip plates, bounce front end several times to settle suspension; if not on plates, roll vehicle several feet and bounce. Check ride height. If desired, increase ride height using shim kit (SPC p/n 95332).
4. Perform alignment, check/confirm torques, road test vehicle.

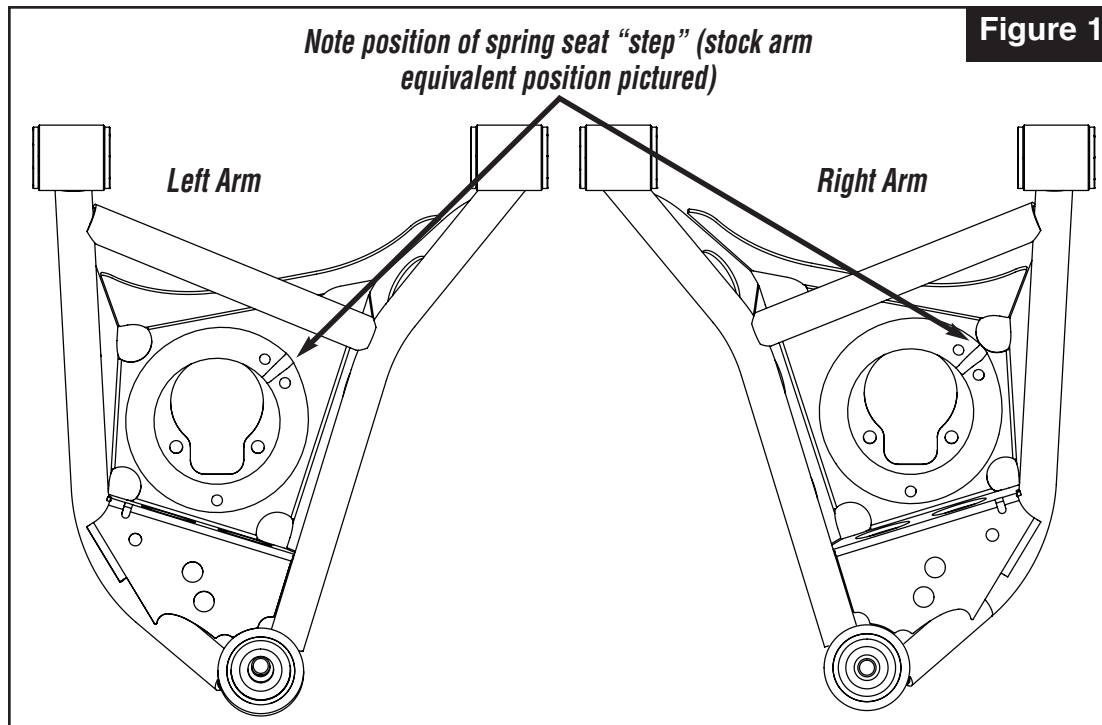

There is no warranty stated or implied due to the inability to monitor the part's modification, installation, and use, except that Specialty Products Company warrants its products to be free from defects in material and workmanship for 90 days after purchase under normal use. In that case, parts returned must be determined by Specialty Products to be defective and Specialty Products's obligations under that warranty are solely limited to repairing or replacing, at its option, any part proven defective.

Final determination of the suitability of the parts for use contemplated by the buyer is the sole responsibility of the buyer. Specialty Products Company shall not be liable for any special, direct, indirect, incidental, or consequential damages that might be claimed as a result of the failure of any part, including claims for delay, loss of profits or labor. Specialty Products Company shall not be liable for any damage or injury to persons or property resulting from improper installation or misuse of any part subject to this warranty. There are no other warranties expressed or implied extending beyond those set forth above.



Specialty Products Company®

P.O. Box 923 • Longmont, CO 80502 • (303) 772-2103 • Fax: (303) 772-1918 • www.specprod.com • www.spcperformance.com • Email: info@specprod.com
Toll Free Technical Hot Line: 1-800-525-6505

©2013 Specialty Products Company® • Printed in U.S.A. • Form No. 983781 • Rev. A 9/13
ECN#1514