

Part no. 94304

SPC
PERFORMANCE

Instruction Sheet
MID SIZE BALL JOINT
LOWERING KIT

This part should only be installed by personnel who have the necessary skill, training and tools to do the job correctly and safely. Incorrect installation can result in personal injury, vehicle damage and / or loss of vehicle control.

This Midsize **BALL JOINT LOWERING KIT** includes 3 spacer plates and hardware to allow more clearance when using GM ball joints (SPC part no. 94006) and either a standard plate assembly (SPC part no. 92006) or 20° plate assembly (SPC part no. Left - 92008, Right - 92009).

Installing plates: Position the plates below the plate assembly as shown in **Figure 2**. Each spacer will add 1/4" of drop.

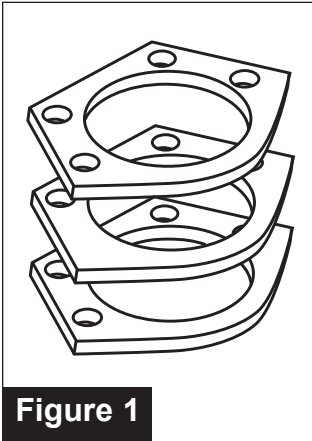

Figure 1

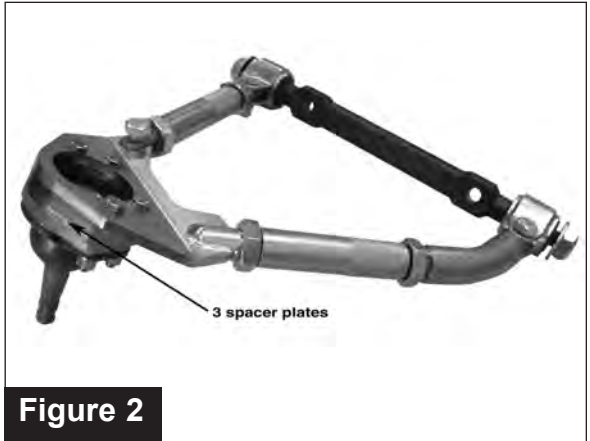

Figure 2

There is no warranty stated or implied due to the inability to monitor the part's modification, installation, and use, except that Specialty Products Company warrants its products to be free from defects in material and workmanship for 90 days after purchase under normal use. In that case, parts returned must be determined by Specialty Products to be defective and Specialty Products's obligations under that warranty are solely limited to repairing or replacing, at its option, any part proven defective.

Final determination of the suitability of the parts for use contemplated by the buyer is the sole responsibility of the buyer. Specialty Products Company shall not be liable for any special, direct, indirect, incidental, or consequential damages that might be claimed as a result of the failure of any part, including claims for delay, loss of profits or labor. Specialty Products Company shall not be liable for any damage or injury to persons or property resulting from improper installation or misuse of any part subject to this warranty. There are no other warranties expressed or implied extending beyond those set forth above.



Specialty Products Company

P.O. Box 923 • Longmont, CO 80502 • (303) 772-2103 • Fax: (303) 772-1918
www.specprod.com • www.spcperformance.com • Email: info@specprod.com
Toll Free Technical Hot Line: 1-800-525-6505

©2005 Niwot Corp. dba Specialty Products Co • Printed in U.S.A. • Form No. 96304 • Rev. 7/05