

“W” CAR REAR TOE TOOL

This part should only be installed by personnel who have the necessary skill, training and tools to do the job correctly and safely. Incorrect installation can result in personal injury, vehicle damage and / or loss of vehicle control.

Applications: 1990 and Newer**Buick:** Regal **Chevrolet:** Lumina Sedan, Monte Carlo**Oldsmobile:** Cutlass Supreme **Pontiac:** Grand Prix

1. Loosen the inner control arm nut on the side that the adjustment is to be made.
2. Turn the turnbuckle on the tool so that one end fits in the hole in the rear lower control arm, and the other end fits securely into the hole in the center frame bracket.
3. Turn the turnbuckle of the adjusting tool to make a toe change. (Shorten for toe-out. Lengthen for toe-in.)

Always check for proper clearance between suspension components and other components of the vehicle.

4. Adjust toe to manufacturer's specifications.
5. Tighten inner control arm bolt to manufacturer's specifications.
6. Remove tool and follow the same procedure to adjust rear toe on the other side of the vehicle.

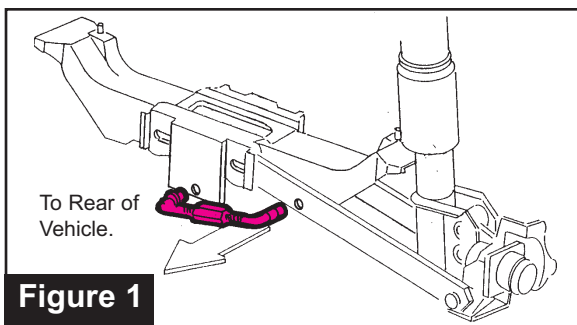
**Figure 1****Specialty
Products
Company**

P.O. Box 923 • Longmont, CO 80502 • (303) 772-2103

www.specprod.com • www.spcperformance.com

Email: info@specprod.com

Printed in U.S.A.

Toll Free Technical Hot Line: 1-800-525-6505

©2005 Niwot Corp. dba Specialty Products Co. • Form No. 99825 • Rev. 2/05