

**JEEP GRAND CHEROKEE/DODGE
DURANGO CAMBER KIT**

This part should only be installed by personnel who have the necessary skill, training and tools to do the job correctly and safely. Incorrect installation can result in personal injury, vehicle damage and / or loss of vehicle control.

1. Before beginning any alignment always check for loose or worn parts, tire pressure, and odd tire wear patterns.
2. Remove forward lower control arm nut leaving factory bolt in place.
3. Install new cam plate, roughly centering cam plate slot on factory cam plate slot, then install and tighten supplied M6x20mm retention bolt. **(See Figure 1)**
4. Install threaded cam nut, and lightly tighten so cam may still be rotated for adjustment.
5. Adjust camber by turning cam nut until desired specifications are reached.
6. Tighten lower control arm mounting bolt to factory specifications. Be careful not to rotate cam nut.

Always check for proper clearance between suspension components and other components of the vehicle.

7. Recheck alignment readings and road test vehicle.

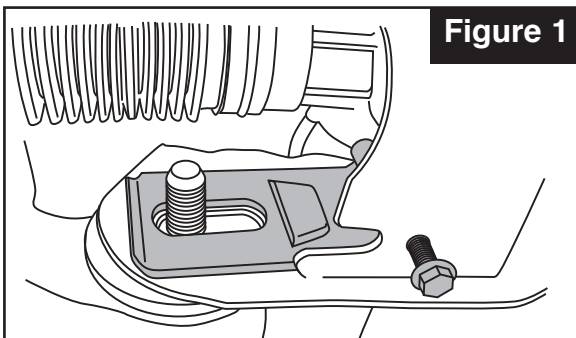
**Figure 1**

**Specialty
Products
Company**®

P.O. Box 923 • Longmont, CO 80502 • (303) 772-2103

www.specprod.com • www.spcperformance.com

Email: info@specprod.com

Printed in U.S.A.

Toll Free Technical Hot Line: 1-800-525-6505

©2012 Niwot Corp. dba Specialty Products Co. • Form No. 983602 • Rev. 9/12