

SPC

PERFORMANCE®

Instruction Sheet - Infiniti/Nissan Rear Kit

Check out the **INSTALLATION VIDEO** at: <http://spc-tv.com>



This part should only be installed by personnel who have the necessary skill, training and tools to do the job correctly and safely. Incorrect installation can result in personal injury, vehicle damage and / or loss of vehicle control.

Before beginning alignment check for loose or worn parts, proper tire pressures, and odd tire wear patterns. Replace any loose or worn parts.

Plan Ahead - Read All Instructions **BEFORE** installing part.

1. Raise vehicle by frame and support properly by frame.
 - A. Place a jack under coil spring seat. This will be used to control the lower control arm in Step 6.
2. Remove rear wheel and tire.
3. Remove lower camber link.
4. **IMPORTANT! Setting arm length:**
 - A. *For 72052:*
 1. Ensure both ends of adjustable arm have equal threads showing on either side of turnbuckle.
 2. Rotate turnbuckle, while holding bushing and clevis stationary, until adjustable arm is approx. same length as stock arm.
 - B. *For 72262:*
 1. Fully screw both ends into turnbuckle.
 2. Measure bolt hole center-to-center distance of stock arm.
 3. If stock arm is ~12-7/8", unthread bushing end only 15 turns. If stock arm is ~12-3/8", unthread bushing end 7 turns.
 4. Rotate turnbuckle, while holding bushing and clevis stationary, until adjustable arm is approximately same length as stock arm.

5. Install adjustable arm into vehicle with bushing end toward center of vehicle. Using original bolts, replace nut-side cam with supplied lock plate. Tighten bolts slightly with remaining cam in neutral position.
6. Remove stock toe cam bolt and drop arm down out of the way by raising vehicle slightly, or lowering the jack under the coil seat on this arm.

Note: On some applications the rear spring may need to be removed so inner pivot of arm can swing down due to the frame pocket wrapping around arm.

CAUTION: Always use appropriate safety devices to support the weight of the vehicle while servicing any suspension component.

7. Mark area to elongate slots on both sides by using the supplied template. The template should be centered over the existing slots in the vehicle.
8. Use #85130 Rotary File Set or equivalent to elongate slots. Check to make sure hole is the right size by placing the new bolt with a cam on the head into the hole, it should be able to rotate 360 degrees.
9. Reinstall control arm by raising the jack supporting arm and install the bolt with a cam on either side. Install locknut and tighten slightly. On vehicles where the spring was removed, reinstall it prior to replacing the control arm.
10. Lower vehicle and adjust toe and camber using the new toe cam bolt and the new camber arm. When all adjustments are made tighten all fasteners including adjustable control arm jam nuts.

Note: the maximum length of the arm is reached when the flat on one rod is visible at the end of the turnbuckle adjuster.

DO NOT lengthen the arm beyond this point.

11. Complete vehicle alignment and road test vehicle.

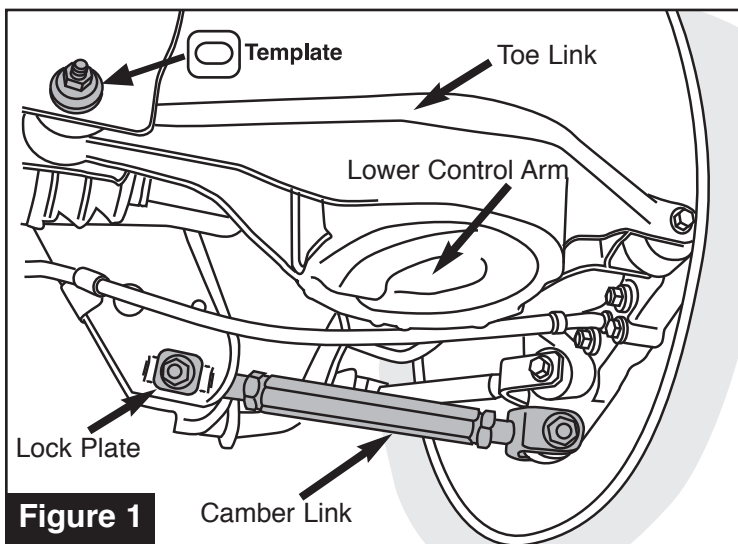
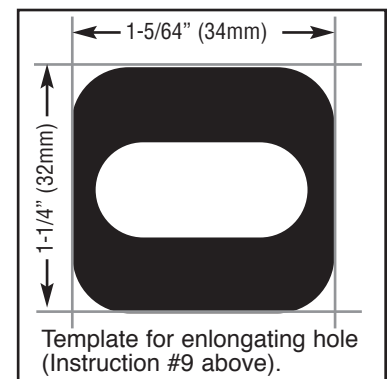

Figure 1



Specialty Products Company®

P.O. Box 923 • Longmont, CO 80502 • (303) 772-2103 • Fax: (303) 772-1918 • www.specprod.com • www.spcperformance.com • Email: info@specprod.com
Toll Free Technical Hot Line: 1-800-525-6505 ©2013 Niwot Corp. dba Specialty Products Co.® • Printed in U.S.A. • Form No. 980521 • Rev. 1/14 • ECN#1548