

PART NO. 67520

Instruction Sheet LEXUS IS & GS REAR CAMBER ARM KIT

This part should only be installed by personnel who have the necessary skill, training and tools to do the job correctly and safely. Incorrect installation can result in personal injury, vehicle damage and / or loss of vehicle control.

This arm kit will adjust rear camber $\pm 3.0^\circ$. Stock toe cam may limit total adjustment range to $\pm 1.5^\circ$.

1. Before beginning any alignment always check for loose or worn parts, tire pressure, and odd tire wear patterns.
2. Raise vehicle by the outer end of the lower control arms and remove wheels.
3. Remove bolts holding upper camber arm in place and remove stock arm.
4. Adjust new arm to approximately the same length as stock arm, making sure the exposed thread portions of EZ Arm are equal length.
5. Install EZ Arm reusing the factory inner bolt.
6. Torque outer flange nut to 45 lbf and tighten further as necessary to install cotter. Tighten inner nut/bolt lightly. Do not fully tighten inboard bolt at this time.
7. Install tires, lower and jounce the vehicle, then tighten inboard upper camber arm bolt to factory specifications.



8. Adjust camber using center turnbuckle to achieve desired readings. The camber adjustment range is limited by the range of rear toe adjustment, and amount of setback that is tolerable in the wheel well.

Always check for proper clearance between suspension components and other components of the vehicle.

9. After adjustment is complete tighten jam nuts against turnbuckle.
10. Complete alignment and road test vehicle.

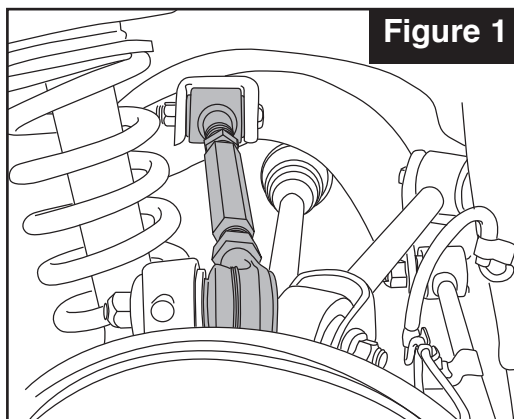

Specialty Products Company®

P.O. Box 923 • Longmont, CO 80502 • (303) 772-2103 • Fax: (303) 772-1918
www.specprod.com • www.spcperformance.com • Email: info@specprod.com
Toll Free Technical Hot Line: 1-800-525-6505

ECN#2123

©2016 Niwot Corp. dba Specialty Products Co® • Printed in U.S.A. • Form No. 985201 • Rev. 5/16