

PART NO. 67220

SPC PERFORMANCE

Instruction Sheet HONDA S2000 ADJUSTABLE BALL JOINT

WARNING - This kit is designed for use only with 17" rims or larger.

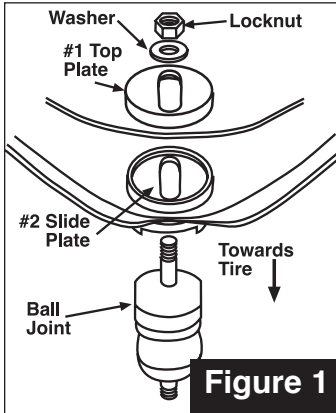

Figure 1

This part should only be installed by personnel who have the necessary skill, training and tools to do the job correctly and safely. Incorrect installation can result in personal injury, vehicle damage and / or loss of vehicle control.

Before beginning any alignment always check for loose or worn parts, tire pressure, and odd tire wear patterns.

NOTE: This product is designed for camber change only.

1. Determine if negative or positive camber change is needed.
3. Raise and support front or rear of vehicle. Remove tire and wheel assembly. Remove cotter pin and nut from upper ball joint.
4. Break ball joint to knuckle taper using tie rod puller SPC tool #8370 or equivalent then press out ball joint using ball joint press SPC tool #40920 or equivalent.
5. Position slide plate (#2) on underside of control arm. Align slot in slide plate so that it points directly towards tire (**Figure #1**) and press into control arm using ball joint press.
6. Position offset of stud toward **INSIDE** of car for positive change and toward **OUTSIDE** of car for negative change (**Figure #2**). Install ball joint through slot and align machined grooves. Install top plate (#1) with recessed area down over flange on control arm. Install washer and locknut making sure washer fits onto recessed area of nut.
7. Install ball joint stud into knuckle, torque nut to manufacturer's specification and install cotter pin.
8. Reinstall tire and wheel assembly. Install alignment equipment and re-compensate.
9. Adjust for correct camber by slightly loosening top lock nut and sliding joint in or out.

NOTE: JOINT WILL SLIDE WHEN NUT IS LOOSE. USE CARE WHEN MAKING ADJUSTMENTS.

10. Tighten top lock nut to 120 lb-ft.
11. Re-check camber, set toe and road test vehicle

Always check for proper clearance between suspension components and other components of the vehicle.

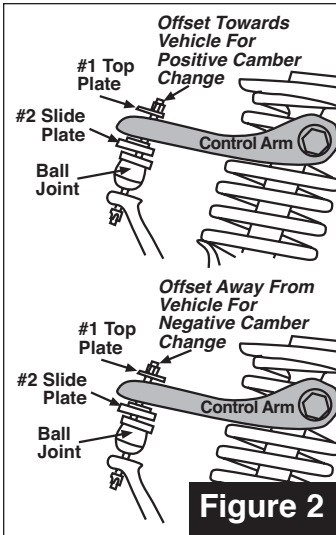

Figure 2



Specialty Products Company®

4045 Specialty Pl. • Longmont, CO 80504 • (303) 772-2103 • Fax: (303) 772-1918

Toll Free Technical Hot Line: 1-800-525-6505 • www.specprod.com ECN#2644

For warranty information go to: www.specprod.com/warranties • Email: info@specprod.com

©2019 Niwot Corp. dba Specialty Products Co • Printed in U.S.A. • Form No.67220INS • Rev. 2/19