



Cupped Foot & Domed Target Custom JounceShock™ Application

This part should only be installed by personnel who have the necessary skill, training and tools to do the job correctly and safely. Incorrect installation can result in personal injury, vehicle damage and / or loss of vehicle control.

Read instructions completely before beginning installation.

Required Tools:

- 1/4" pin style spanner
- Drill motor and Drill Index or:
- Welding Equipment

- #25601 Cupped Foot (Delrin - Medium Hard) & Target
- #25606 Cupped Foot (90 Durometer Rubber - Medium)
TARGET NOT INCLUDED
- #25612 Cupped Foot (75 Durometer Rubber - Soft)
TARGET NOT INCLUDED
- #25613 Cupped Foot (90 Durometer Rubber - Medium) & Target

Using the Cupped Foot and Domed Target:

The Cupped Foot is intended to mate precisely with the domed target to provide a virtual spherical interface which allows articulating contact without the more common relative scrubbing motion. Notice that this is a very low profile joint as compared to a typical spherical rod end mount, and has a relatively large surface contact area as well. Once engaged, this Cupped Foot and Domed Target work together to maintain the alignment of the JounceShock as the suspension travels. This shaft end interface system is intended to be used with an articulating upper mount such as our 15° Flex Mount (#25501).

The Cupped foot is made from high impact plastic and the OD spanner wrench holes allow for easy installation and removal. It simply threads into the shaft end of the JounceShock or shaft extender.

The Domed Target is a zinc plated carbon steel spherical target which receives and locates the JounceShock once they are in contact, and can accommodate up to 30 degrees of relative motion with the Cupped Foot. It has a threaded hole in the bottom center for easy drill through installation in most applications. The Domed Target can also be welded on to many suspension components for an even more robust mount or when the bolt up possibilities are limited. Make sure to remove the zinc plating from weld affected areas before welding, and paint these areas after welding to prevent corrosion.

For more information regarding application and use of the JounceShock end mounts and adapters please refer to the Technical Information section of our website www.specprod.com.

Cupped Foot
Material: High Strength Plastic

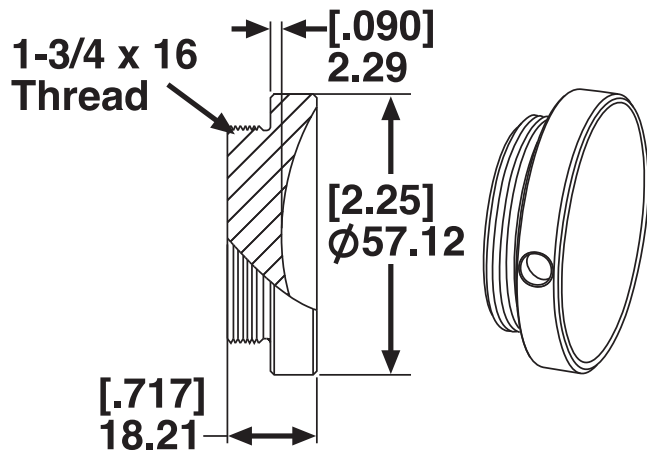

Domed Target
Material: Carbon Steel

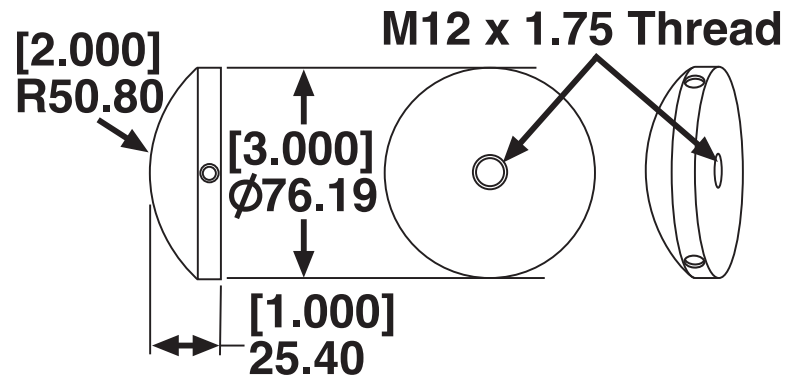

There is no warranty stated or implied due to the inability to monitor the part's modification, installation, and use, except that Specialty Products Company warrants its products to be free from defects in material and workmanship for 90 days after purchase under normal use. In that case, parts returned must be determined by Specialty Products to be defective and Specialty Products's obligations under that warranty are solely limited to repairing or replacing, at its option, any part proven defective.

Final determination of the suitability of the parts for use contemplated by the buyer is the sole responsibility of the buyer. Specialty Products Company shall not be liable for any special, direct, indirect, incidental, or consequential damages that might be claimed as a result of the failure of any part, including claims for delay, loss of profits or labor. Specialty Products Company shall not be liable for any damage or injury to persons or property resulting from improper installation or misuse of any part subject to this warranty. There are no other warranties expressed or implied extending beyond those set forth above.



Specialty Products Company®

P.O. Box 923 • Longmont, CO 80502 • (303) 772-2103 • Fax: (303) 772-1918 • www.specprod.com • Email: info@specprod.com

Toll Free Technical Hot Line: 1-800-525-6505

©2014 Niwot Corp. dba Specialty Products Co. • Printed in U.S.A. • Form No. 986011 • Rev. 6/14