

PART NO. 25440

Instruction Sheet

TOYOTA REPLACEMENT CAMBER/CASTER CAM KIT

This part should only be installed by personnel who have the necessary skill, training and tools to do the job correctly and safely. Incorrect installation can result in personal injury, vehicle damage and / or loss of vehicle control.

Plan Ahead - Read All Instructions BEFORE installing part.

Check for loose or worn parts, proper tire pressure, and odd tire wear patterns before beginning alignment.

1. Raise front of vehicle and support by frame.
2. Pre-assemble SPC cam assemblies by first installing appropriate cam on each bolt, then a tube spacer on larger bolt as shown in **Figure 1**.
3. One at a time, remove original cam assemblies from lower control arm and replace with SPC assembly, installing new assemblies as shown in **Figure 2**.

SPC tool 40915 may help with removal of OEM cams. However, if tubes are solidly seized in bushings, you may not be able to remove them. To achieve camber/caster change, you may need to replace upper control arms with SPC Part No. 25470 or 25480 (check applications).

4. Install appropriate remaining cam and nut on each bolt and loosely tighten.

NOTE: Tightening fasteners with vehicle in raised position may cause premature bushing failure.

NOTE: Ensure that washer is between cam and nut on M18 bolt as shown in **Figure 1.**

5. Lower vehicle and adjust alignment to desired settings by turning bolts.
6. Torque front bolt (M18) to **157 ft-lbs** and torque rear bolt (M16) to **149 ft-lbs**
7. Adjust toe and road test vehicle.

Always check for proper clearance between suspension components and other components of vehicle.

Figure 1

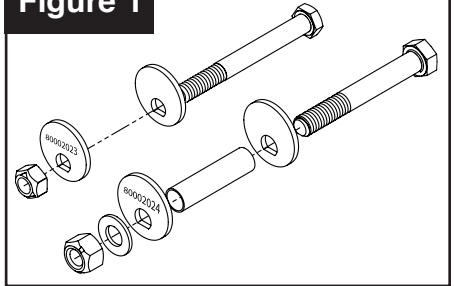
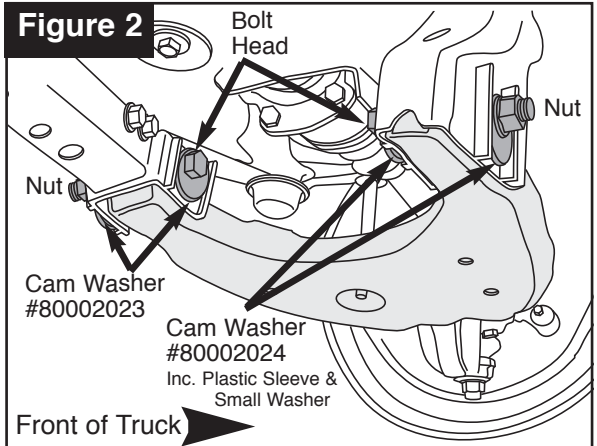

Figure 2



Specialty Products Company®

P.O. Box 923 • Longmont, CO 80502 • (303) 772-2103 • Fax: (303) 772-1918

www.specprod.com • www.spcperformance.com • Email: info@specprod.com

Toll Free Technical Hot Line: 1-800-525-6505

ECN#2154

©2016 Niwot Corp. dba Specialty Products Co® • Printed in U.S.A. • Form No. 984402 • Rev. 7/16