



This part should only be installed by personnel who have the necessary skill, training and tools to do the job correctly and safely. Incorrect installation can result in personal injury, vehicle damage and / or loss of vehicle control.

**Plan Ahead - Read All Instructions BEFORE installing part.**

Check for loose or worn parts, proper tire pressure, and odd tire wear patterns before beginning alignment.

1. Take initial alignment readings and determine caster change needed.
2. Raise vehicle by frame and securely support.
3. Remove front tire and wheel assembly.
4. Set lower control arm cam bolts to center, neutral positions and lightly tighten.
5. Loosen nut on OE upper arm-to-frame mounting bolt. Remove bolt holding ABS wiring to OE upper control arm.
6. Remove cotter pin and nut holding OE ball joint to upper control arm. Break taper between ball joint stud and arm, then separate ball joint from arm.  
**NOTE: Support steering knuckle to avoid strain to brake lines or ABS wires.**
7. Remove nut and washer from long arm-to-frame mounting bolt. Remove bolt and OE upper control arm. Discard OE washers.  
**NOTE: To provide clearance, additional components in engine compartment may need to be removed.**
8. Remove snap ring retaining OE upper ball joint into knuckle. Press out ball joint using SPC #72509 ball joint press or equivalent.
9. Press supplied steering knuckle insert into knuckle with flange on bottom, see **Figure 1**.

10. Install supplied snap ring on top side to retain insert. Verify snap ring is seated in groove of insert.  
**NOTE: Depending on condition of knuckle, supplied insert may not fit tightly into knuckle receiver. Knuckle insert will expand when SPC ball joint stud is inserted.**
11. Using **SUPPLIED GREASE ONLY**, liberally coat inside of all four SpecRide™ control arm bushings, making sure all small voids are filled with grease. Press a pivot sleeve into each bushing until it is flush with outside of bushing. This will push some grease out, which is normal. Use this grease to lightly coat outboard ends of SpecRide™ bushings where they will contact washers, see **Figure 1**.
12. Place one supplied washer on OE bolt. Using OE bolt, install SPC control arm onto vehicle. Add second supplied washer just before the nut and torque to manufacturer's specifications.

**NOTES:**

- 1) The OE 'dished' washers are not to be re-used.
- 2) Unlike OE rubber bushings, SpecRide™ bushings pivot freely and can be torqued without applying vehicle weight.

13. Install star plate over hex on SPC ball joint per chart below to achieve desired caster change determined in Step 1 above.  
**NOTE: For most trucks with 2-3" of lift, setting "D" should return caster to manufacturer's specifications, but it may be necessary to use different positions on each side to achieve desired cross-caster setting.**
14. Insert SPC ball joint up through bottom of SPC arm, indexing star plate in machined slot, and then install supplied top washer and nut. Position ball joint approximately in middle of slot and snugly tighten top nut.
15. Insert SPC ball joint stud into knuckle insert, install supplied castle nut, and torque nut to 45 ft-lb [61 Nm]. Tighten nut further, but only until cotter pin can be installed. Install supplied cotter pin.
16. Re-attach OE ABS wiring bracket to SPC arm using OE bolt. Torque to manufacturer's specifications.
17. Re-install tire and wheel assembly. Lower vehicle and take alignment readings. If additional caster adjustment is necessary, loosen top nut and reposition star plate to rotate ball joint relative to arm. Adjust camber with SPC arm by loosening top nut and sliding ball joint in control arm slot.  
**NOTE: It will be necessary to raise vehicle to make camber/caster adjustments with SPC arm.**

18. With full vehicle weight on suspension, fine-tune alignment using lower control arm cam bolts.  
**NOTE: Camber and caster can be set with SPC upper control arm, as well as lower control arm cam bolts. In most cases, it is recommended that lower cam bolts be set to their neutral position. This way, they can be used to fine-tune caster setting. Alternately, if caster is set to max positive with lower cam bolts, and final alignment achieved with SPC upper ball joint setting, more tire clearance may be obtained at rear of wheel opening. To do this, push rear lower adjuster outward, towards tire, and pull front lower adjuster inward, towards center of vehicle. The lower control arm adjusters are far more efficient at creating clearance. This typically requires using ball joint position "E".**

19. When final caster/camber settings are achieved, torque top ball joint nut to **200 ft-lb [271Nm]**. Torque OE lower cams to manufacturer's specifications. Adjust toe and road test vehicle.

Always check for proper clearance between suspension components and other components of vehicle.

**Maintenance:**

This ball joint is fully sealed and features a lifetime grease. No maintenance is required after installation.

**Figure 1**

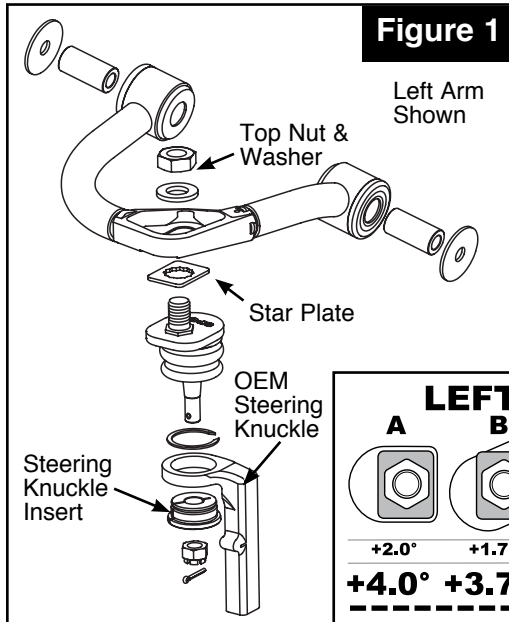

LEFT FRONT CASTER CHANGE							
A	B	C	D	E	F	G	
+2.0°	+1.75°	+1.0°	0°	-1.0°	-1.75°	-2.0°	Ball Joint Setting
<b>+4.0°</b>	<b>+3.75°</b>	<b>+3.0°</b>	<b>+2.0°</b>	<b>+1.0°</b>	<b>+0.25°</b>	<b>0.0°</b>	<b>Total Arm + Ball Joint Caster Change</b>
RIGHT FRONT CASTER CHANGE							
A	B	C	D	E	F	G	
+2.0°	+1.75°	+1.0°	0°	-1.0°	-1.75°	-2.0°	Ball Joint Setting
<b>+4.0°</b>	<b>+3.75°</b>	<b>+3.0°</b>	<b>+2.0°</b>	<b>+1.0°</b>	<b>+0.25°</b>	<b>0.0°</b>	<b>Total Arm + Ball Joint Caster Change</b>

Note: With flat face of joint facing the tire (Position D), this arm will give +2° additional caster. Using the star plate, caster change can be adjusted from +0.0° to +4.0°.



**Specialty Products Company®**

4045 Specialty Place • Longmont, CO 80504 • (303) 772-2103 • Fax: (303) 772-1918 • www.specprod.com • Email: info@specprod.com  
Toll Free Technical Hot Line: 1-800-525-6505 • For warranty information go to: www.specprod.com/warranties